

One-Way Flow Altitude Control Valve

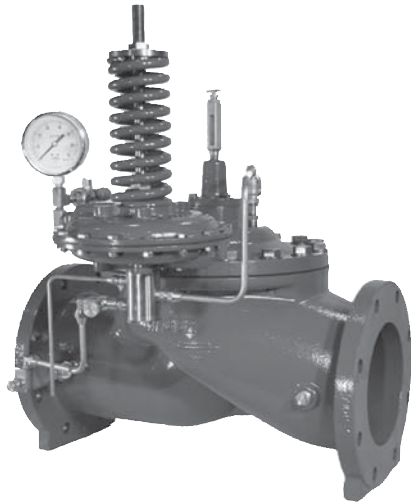

The Singer model A-Type 2 altitude control valve employs the basic Singer model 106-PG or 206-PG main valve. The valve functions as a two position control valve - either fully open or fully closed.

The Type 2 allows normal forward flow to fill the reservoir to the maximum level, then closes drip tight at the set point. It opens to refill the tank once the level drops a fixed distance below the high water level.

Note: This valve does not prevent reverse flow

- NO OVERFLOW - HIGH LEVEL SHUT-OFF MAINTAINED TO CLOSE TOLERANCES
- OPERATES WITHIN CLOSE LIMITS WITH SUPERIOR REPEATABILITY
- POSITIVE SHUT OFF
- ALL SERVICE AT GROUND LEVEL

Typical Application:

When Ordering Please Specify:

1. Catalog Model # 2. Full Port (106) or Reduced Port (206) (See Main Valves) 3. Globe or Angle Pattern 4. End Connections
 5. Valve Size 6. Pilot Range

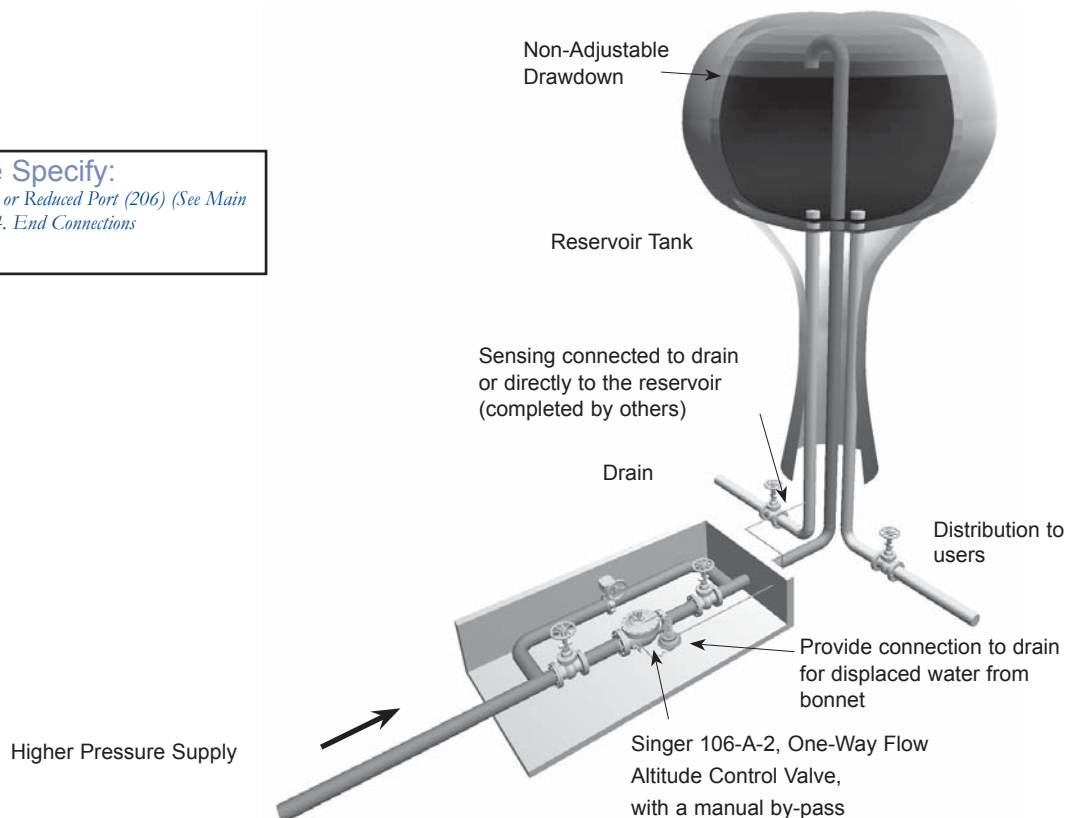

Level Control

One Way Flow Altitude Control

1. Main Valve - 106-PG or 206-PG - with X107 position indicator
2. Strainer - 40 mesh stainless steel screen
3. Model 301-4 Altitude Pilot
4. Closing Speed Control
5. Altitude Gauge
6. Isolation Valve
7. Union
8. Isolation Valve
9. SENSING CONNECTION TO RESERVOIR (complete in field by others)
10. Isolation Valve

Standard materials for pilot system components are:

- Ductile Iron
- Stainless Steel

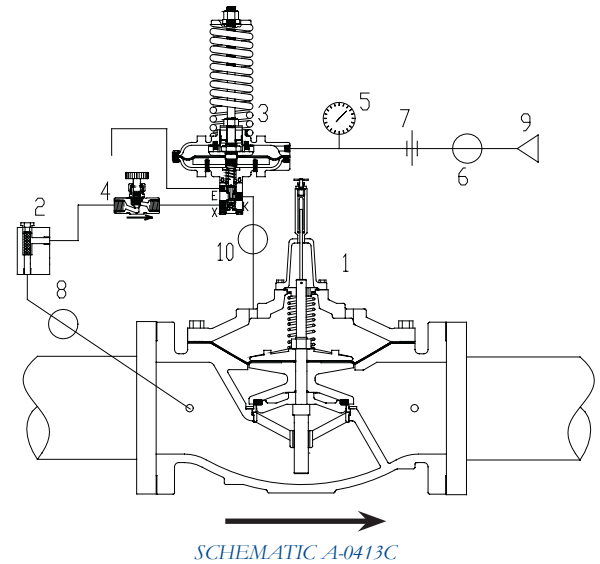

106-A-Type2	Flow Coefficient CV (See 106-PG in Main Valve Section for other Valve Data)			
Size (inches)	3"	4"	6"	8"
Size (mm)	80mm	100mm	150mm	200mm
CV*	110	200	460	800
CV**	2.6	4.8	11.0	19.2

206-A-Type 2	Flow Coefficient CV (See 206-PG in Main Valve Section for other Valve Data)			
Size (inches)	3"	4"	6"	8"
Size (mm)	80mm	100mm	150mm	200mm
CV*	60	150	250	505
CV**	1.4	3.6	6.0	12.1

106-A-Type2	Flow Coefficient CV (See 106-PG in Main Valve Section for other Valve Data)						
Size (inches)	10"	12"	14"	16"	20"	24"	36"
Size (mm)	250mm	300mm	350mm	400mm	500mm	600mm	900mm
CV*	1300	2100	2575	3300	7500	7600	16340
CV**	31.2	50.4	61.8	79.2	180.0	182.4	392.2

206-A-Type 2	Flow Coefficient CV (See 206-PG in Main Valve Section for other Valve Data)									
Size (inches)	10"	12"	16"	18"	20"	24"	28"	30"	32"	36"
Size (mm)	250mm	300mm	400mm	450mm	500mm	600mm	700mm	750mm	800mm	900mm
CV*	985	1550	2200	3300	3400	3500	7800	7800	7900	8000
CV**	23.6	37.2	52.8	79.2	81.6	84.0	187.2	187.2	189.0	192.0

* CV = USGPM at 1 psi pressure drop; ** CV = L/s at 1 kPa pressure drop $(Q=C_v \sqrt{\Delta P})$
Note: based on fully open valve with pilot system vented to atmosphere

Main Valve Dimensions
106-PG Page 20
206-PG Page 29
Anti-Cav Page 82

Selection Summary:

1. Generally select line size to minimize losses during normal forward flow.
2. Use the performance curves and sizing bulletin to determine the pressure drop across the valve (see Technical & Sizing Section).
3. Maximum continuous flow - 106 is 20 ft/s (6 m/s), 206 is 16 ft/s (5m/s). Consult factory if higher flows are expected.
4. The pilot system exhausts to atmosphere ensuring the valve opens fully; requires that the displaced volume of water be taken to drain with each opening.
5. Select pilot spring range. Standard (301-4) is 10 to 60 ft (3 to 18m). Specify for 301-4 ranges 4 to 20 ft (1 to 6m), 40 to 125 ft (12 to 38m), 60 to 220ft (18 to 67m).
6. There is a non-adjustable differential required between the reservoir head and the supply pressure in order for the valve to open. Level drop (differential) required to open: 2 ft, 3 ft or 4 ft (.75m, 1m, 1.5m) (approximate).
7. If the fill line discharges below the reservoir surface, an internal drop check or separate check valve is suggested. This prevents return flow on loss of supply pressure.

Specifications:

The valve shall be a Singer Valve model 106 (206) -A-Type 2, size "____", ANSI Class 150 (ANSI 300, ANSI flanges drilled to ISO PN 10 / 16/ 25 or 40) pressure rating/ flange standard, globe (angle), style valve. The Model 301-4 Altitude Pilot spring range (elevation) shall be "___ to ___" feet (meters), with set point preset at factory to "___" feet (meters). Assembly shall be according to Schematic A-0413C.

- The valve allows normal forward flow to fill the reservoir to the maximum level then closes drip tight at the set point. It opens to refill the tank once the level drops a fixed distance below the high water level.

Refer to "Main Valve" section, 106-PG (or 206-PG) and "Main Valve Options" section, Model X107 Position Indicator for detailed information pertaining to valve sizes and materials, selection criteria and specifications.

Refer to "Pilot and Accessories" section, Model 301-4 Altitude Pilot for detailed information pertaining to materials and specifications.