

Two-Way Flow Altitude Control Valve with Differential Control

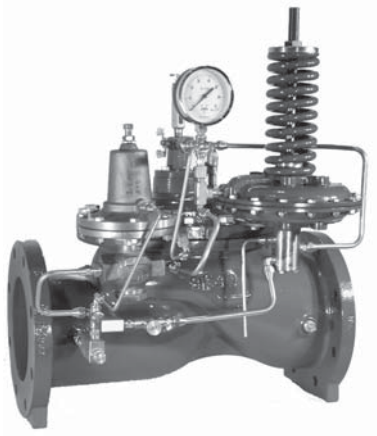

The Singer model A-Type 3 altitude control valve employs the basic Singer model 106-PG or 206-PG main valve. The valve functions as a two position control valve - either fully open or fully closed.

The Type 3 allows normal forward flow to fill the reservoir to the maximum level, then closes drip tight at the set point.

The valve opens to permit reverse flow through the valve when the supply pressure drops an adjustable amount below the reservoir head.

The Type 3 will then allow normal forward flow to refill the tank to the maximum level, when a higher supply pressure is restored.

- NO OVERFLOW - HIGH LEVEL SHUT-OFF MAINTAINED TO CLOSE TOLERANCES
- PRESSURE DIFFERENTIAL REQUIRED FOR OPENING IS ADJUSTABLE
- OPERATES WITHIN CLOSE LIMITS, WITH SUPERIOR REPEATABILITY
- POSITIVE SHUT OFF

When Ordering Please Specify:

1. Catalog Model #
2. Full Port (106) or Reduced Port (206) (See Main Valves)
3. Globe or Angle Pattern
4. End Connections
5. Valve Size
6. Pilot Ranges

Typical Application:

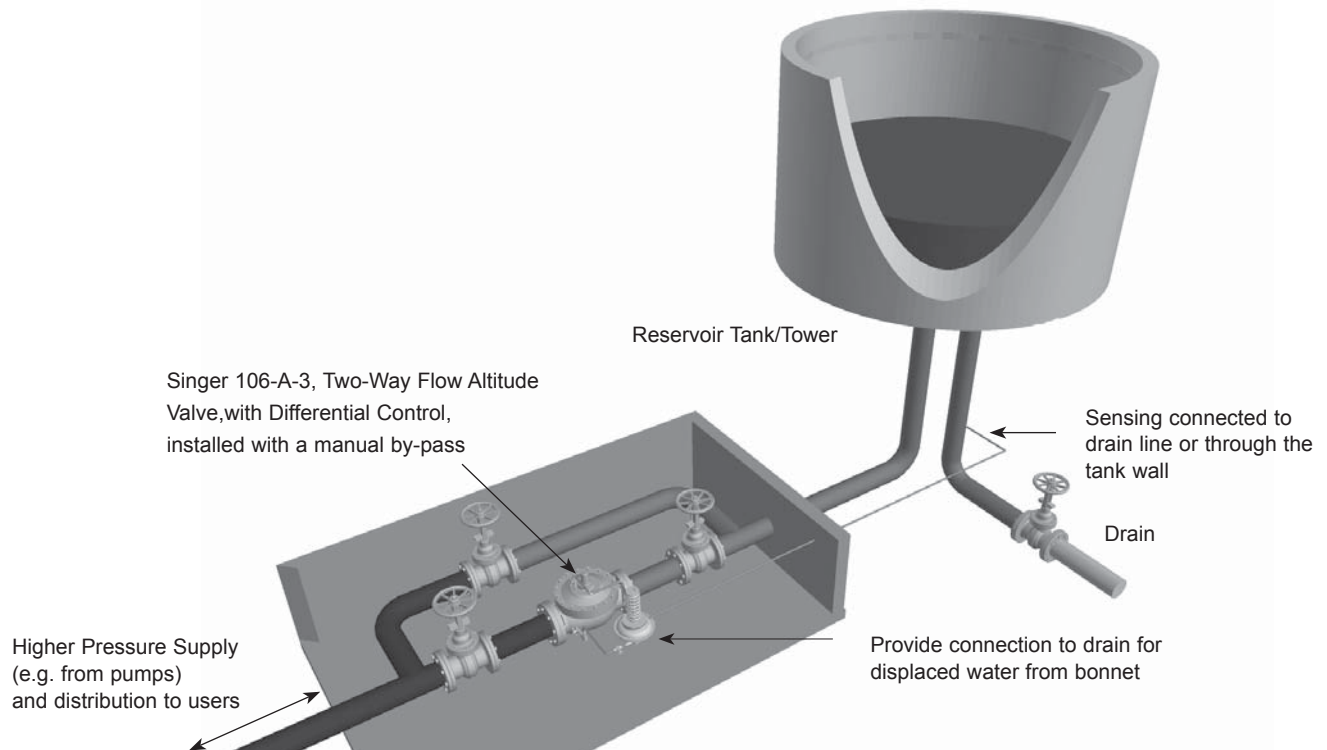

Two Way Flow Altitude Valve With Differential Control

1. Main Valve - 106-PG or 206-PG - with X107 position indicator
2. Isolation Valve
3. Strainer - 40 mesh stainless steel screen
4. Model 10 Check Valve
5. Closing Speed Control
6. Model 625-RPD Differential Relief Pilot
7. Altitude Gauge
8. Isolation Valve
9. SENSING CONNECTION TO RESERVOIR - complete in field
10. Union
11. Fixed Restriction - 1/8" (3.5mm)
12. Model 301-4 Altitude Pilot;
13. Isolation Valve

Standard materials for pilot system components are:

- Ductile Iron
- Stainless Steel

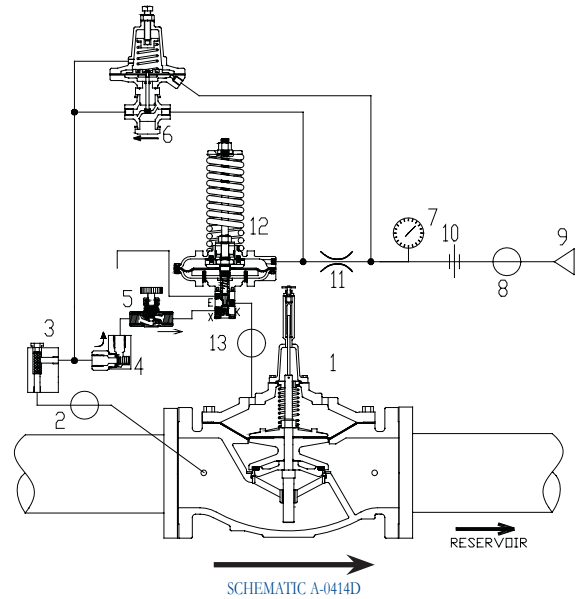

106-A-Type3	Flow Coefficient CV (See 106-PG in Main Valve Section for other Valve Data)			
Size (inches)	3"	4"	6"	8"
Size (mm)	80mm	100mm	150mm	200mm
Cv*	110	200	460	800
Cv**	2.6	4.8	11.0	19.2

206-A-Type 3	Flow Coefficient CV (See 206-PG in Main Valve Section for other Valve Data)			
Size (inches)	3"	4"	6"	8"
Size (mm)	80mm	100mm	150mm	200mm
Cv*	60	150	250	505
Cv**	1.4	3.6	6.0	12.1

106-A-Type3	Flow Coefficient CV (See 106-PG in Main Valve Section for other Valve Data)						
Size (inches)	10"	12"	14"	16"	20"	24"	36"
Size (mm)	250mm	300mm	350mm	400mm	500mm	600mm	900mm
Cv*	1300	2100	2575	3300	7500	7600	16340
Cv**	31.2	50.4	61.8	79.2	180.0	182.4	392.2

206-A-Type 3	Flow Coefficient CV (See 206-PG in Main Valve Section for other Valve Data)										
Size (inches)	10"	12"	16"	18"	20"	24"	28"	30"	32"	36"	
Size (mm)	250mm	300mm	400mm	450mm	500mm	600mm	700mm	750mm	800mm	900mm	
Cv*	985	1550	2200	3300	3400	3500	7800	7800	7900	8000	
Cv**	23.6	37.2	52.8	79.2	81.6	84.0	187.2	187.2	189.0	192.0	

* CV = USGPM at 1 psi pressure drop; ** CV = L/s at 1 kPa pressure drop; $(Q=Cv \sqrt{\Delta P})$
 Note: based on fully open valve with pilot system vented to atmosphere

Main Valve Dimensions
 106-PG Page 20
 206-PG Page 29
 Anti-Cav Page 82

Level Control

Selection Summary:

1. Generally select line size to minimize losses during normal forward flow.
2. Use the performance curves to determine the pressure drop across the valve (see Technical & Sizing Section).
3. Limit maximum continuous flow velocity to less than 20 ft/s (6 m/s) for 106 and less than 16 ft/s (5m/s) for 206.
4. The pilot system exhausts to atmosphere ensuring the valve opens fully; requires that the displaced volume of water be taken to drain with each opening - refer to bulletin 206-PG or 106-PG (see Main Valve Section) for displaced volume
5. Select pilot spring range. Standard (301-4) is 10 to 60 ft (3 to 18m). Specify for 301-4 ranges 4 to 20 ft (1 to 6m), 40 to 125 ft (12 to 38m), 60 to 220 ft (18 to 67m).
6. Select the adjustable differential pilot spring range. Standard is 5 to 15 ft (2 to 5m). Specify for 12 to 30 ft (4 to 10m) or 25 to 50 (8 to 15m). The total differential includes the non-adjustable differential of the altitude pilot.

Specifications:

The valve shall be a Singer Valve model 106 (206) -A-Type 3, size "____", ANSI Class 150 (ANSI 300, ANSI flanges drilled to ISO PN 10 / 16/ 25 or 40) pressure rating/ flange standard, globe (angle), style valve. The Model 301-4 Altitude Pilot spring range (elevation) shall be "___ to ___" feet (meters), with set point preset at factory to "___" feet (meters). The Model 625-RPD differential (delayed opening) range shall be "___" to "___" feet (meters), with set point preset at factory to "___" feet (meters). Assembly shall be according to Schematic A-0414E.

- The valve allows normal forward flow to fill the reservoir to the maximum level then closes drip tight at the set point. It opens to allow reverse flow through the valve to distribute to users when the supply pressure drops an adjustable amount below the reservoir head. When a higher supply pressure is restored the A-Type 3 will then allow normal forward flow to refill the tank to the maximum level.

Refer to "Main Valve" section, 106-PG (or 206-PG) and "Main Valve Options" section, Model X107 Position Indicator for detailed information pertaining to valve sizes and materials, selection criteria and specifications.

Refer to "Pilot and Accessories" section, Model 301-4 Altitude Pilot for detailed information pertaining to materials and specifications. Model 625-RPD Pilot specification information, is available from the factory only at this time.