

Main Valve Option: External Spring Lift

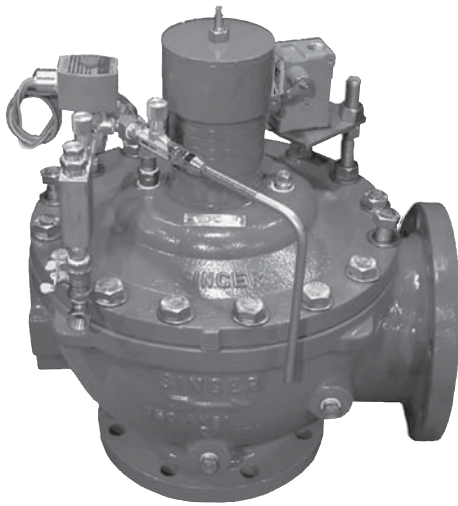

An External Spring Lift assembly opens the valve when the system pressure is insufficient.

This main valve option can be ordered from the factory for either the 106-PG or 206-PG models. When included, the main valve is referred to as a model 106-PGX or 206-PGX.

The PGX main valves are used as standard with the model 106-DWX or 206-DWX deep well pump control valves.

The PGX main valves are also commonly applied to F-4 and F-5 float control applications where there is insufficient line pressure. When a separate source of control pressure is available, a PGX valve can be used to ensure opening.

106-PGX: available from 2" to 8" (50mm to 200mm). 206-PGX available from 4" to 10" (100mm to 250mm)

Refer to bulletins 106-PG and/ or 206-PG (flat diaphragm sizes only) for dimensions, operating specifications and for description of various functions. (Consult factory for height dimensions. Full dimensional drawings are available.)

Standard Materials:

Trip Plate:	Steel - fusion coated
Bonnet Plate:	Steel - fusion coated
Cap screws:	AISI 303 stainless steel
PGX Stem:	AISI 303 stainless steel
Spring:	AISI 302 stainless steel
Guide Bushing:	ASTM B-16 brass
O' ring Seals:	Buna

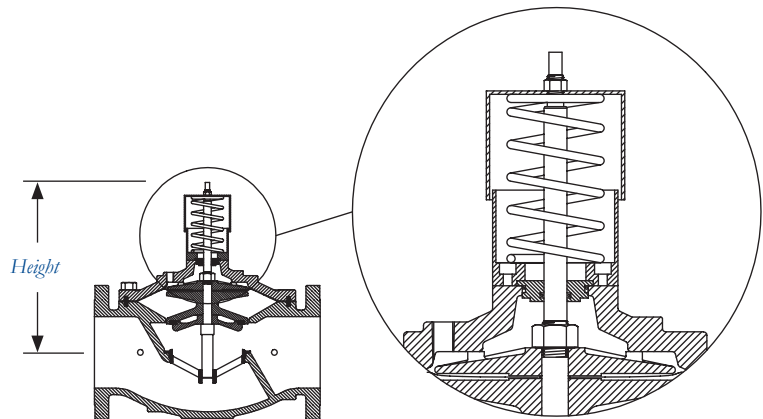

106 External Spring Lift	Height Dimensions					
Size (Inches)	2"	2-1/2"	3"	4"	6"	8"
Size (mm)	50mm	65mm	80mm	100mm	150mm	200mm
Height (Inches)	7.5	9.43	11.06	12.6	15.18	19.4
Height (mm)	191	240	281	321	386	492

206-External Spring Lift	Height Dimensions			
Size (inches)	4"	6"	8"	10"
Size (mm)	100mm	150mm	200mm	250mm
Height (inches)	12.4	13.9	17.63	23.1
Height (mm)	315	354	448	586

When Ordering Please Specify:

1. Catalog Model #.

Please include as addendum to main order. May be included as standard with some products.

Specifications:

Select Singer main valve specifications from the main valve section and incorporate the following addendum:

- The external spring lift option shall be incorporated in the main valve to assist opening of the main valve due to insufficient pressure.
- For safety purposes the external spring shall be fully covered with a metal housing (Trip Plate).
- External spring lift is available on all 106 full port models 2" (50mm) to 8" (200mm), and on all reduced port models from 4" (100mm) to 10" (250mm).

Factory installation is highly recommended.