

Full-Port, Single Chamber, Hydraulically Operated Valve



106-PG Globe

- GLOBE AND ANGLE STYLE
- STABLE LOW FLOW
- PREMIUM MAINTENANCE FEATURES
- EVERY VALVE FACTORY TESTED
- HIGH PRESSURE DROP OPTION (SEE ANTI-CAVITATION IN THE HIGH-PERFORMANCE SECTION)

Singer Model 106-PG series control valves are hydraulically operated by introducing or releasing water from the control chamber above the diaphragm / inner valve assembly.

The Model 106-PG is usually combined with Singer specific purpose pilots and accessories to provide control for a wide range of functions: typically controlling pressure, flow or level, in almost limitless combinations to suit particular applications. Basic valve options greatly extend the range of application. (See Main Valve Options, High-Performance, Standard Models, and Pilots & Accessories Sections).

Options



106-PG Angle



106-PG Thread

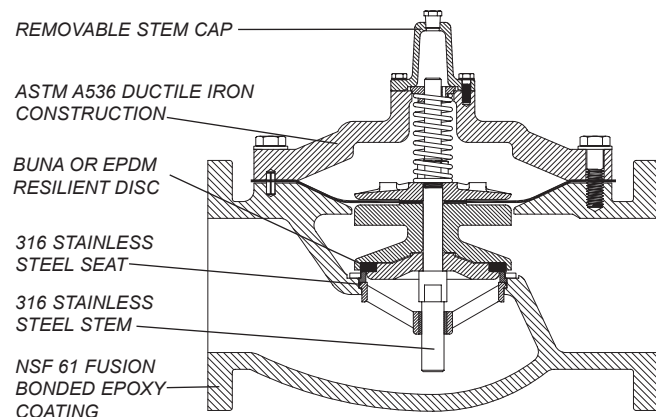

When Ordering Please Specify:

1. Catalog Model #
2. Globe or Angle Pattern
3. End Connections
4. Valve Size
5. Fluid Being Handled
6. Fluid Temperature Range
7. Inlet/Outlet Pressure Range
8. Min./Max. Differential pressure
9. Min./Max. Flow Rate
10. Options (see Main Valve Options/ Pilots & Accessories)

Valve Sizes & Materials:

Valve Materials					
Standard		Optional			
Ductile		Bronze	Steel	Stainless Steel	
Available Sizes	Threaded	Flanged	Flanged & Thread	Flanged Only	Flanged & Thread
Globe	1/2 to 3" (15-80mm)	1-1/2" to 24" (40-600mm)	1/2" to 6" (15-150mm)	2" to 8" (50-200mm)	2" to 8" (50-200mm)
Angle	1" to 3" (25-80mm)	2" to 12", 16" (50-300mm, 400mm)	N/A	N/A	N/A
Valve Components					
1. Valve Body, Cover	ASTM A 536 - 65/45/12 Ductile Iron		ASTM B62 Bronze	ASTM A216 Cast Steel	AISI 316 Stainless Steel
2. Seat Ring	AISI 316 Stainless Steel				
3. Disc Retainer	B16 Brass / B62 Bronze / A48 or A536 Ductile Iron				AISI 316 Stainless Steel
4. Stem	AISI 316 Stainless Steel				
5. Stem Nut	B16 Brass		AISI 316 Stainless Steel		
6. Spring	302 Stainless Steel		316 Stainless Steel		
7. Guide Bushings	B16 Brass or SAE 660 Bronze				AISI 316 Stainless Steel
8. Diaphragm	EPDM / Buna-N		EPDM / Buna-N / Viton (limited sizes)		
9. Resilient Disc	EPDM		Buna-N / Viton (limited sizes)		
10. Coating	NSF61 Approved Fusion Bonded Epoxy				
11. Fasteners	AISI 18-8 Stainless Steel		AISI 316 Stainless Steel		

* Note: Stainless Steel Option - Threaded in 2" (50mm) only

Model 106-PG

Globe Style
Flat Diaphragm

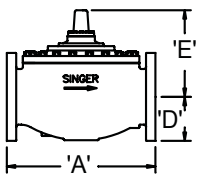

Angle Style
Flat Diaphragm

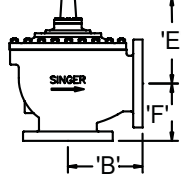

Globe Style
Rolling Diaphragm

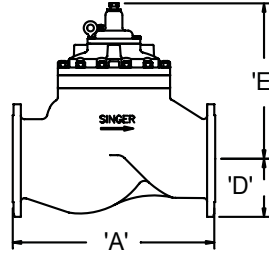

Angle Style
Rolling Diaphragm

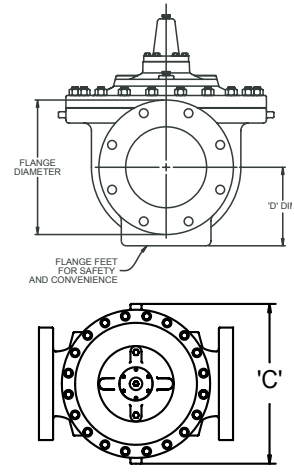
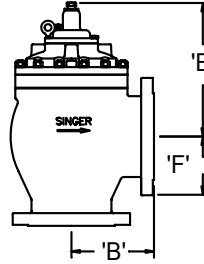

ANSI Valve Data (US Units):

Size	DWG	Standard	Flat Diaphragm System												Rolling Diaphragm System					
			1/2"	3/4"	1"	1-1/4"	1-1/2"	2"	2-1/2"	3"	4"	6"	8"	10"	12"	14"	16"	20"	24"	
All figures shown in inches unless otherwise stated																				
Globe Dimensions																				
Lay Length	A	FNPT	4.50	4.50	6.75	6.75	6.75	9.38	11.00	13.50	-	-	-	-	-	-	-	-	-	
Centerline to Bottom	D	FNPT	1.75	1.75	2.50	2.50	2.50	2.75	3.38	3.68	-	-	-	-	-	-	-	-	-	
Lay Length	A	150F	-	-	-	-	8.50	9.38	11.00	12.00	15.00	20.00	25.38	29.75	34.00	31.00	41.38	67.63	61.50	
Centerline to Bottom	D	150F	-	-	-	-	2.75	3.00	3.50	3.75	4.60	5.60	7.63	8.56	9.50	10.50	11.75	17.16	17.13	
Lay Length	A	300F	-	-	-	-	9.00	10.00	11.63	13.25	15.63	21.00	26.38	31.12	35.50	32.50	43.50	69.19	63.25	
Centerline to Bottom	D	300F	-	-	-	-	3.25	3.25	3.75	4.13	5.09	6.34	7.88	9.31	10.25	11.50	12.75	17.16	19.65	
Angle Dimensions																				
Center Inlet to Discharge	B	FNPT	-	-	3.38	3.38	3.38	4.69	5.50	6.63	-	-	-	-	-	-	-	-	-	
Center Discharge to Inlet	F	FNPT	-	-	3.00	3.00	3.00	3.25	4.00	4.63	-	-	-	-	-	-	-	-	-	
Center Inlet to Discharge	B	150F	-	-	-	-	-	4.75	5.50	6.06	7.50	10.00	12.75	11.50	13.75	-	18.00	-	-	
Center Discharge to Inlet	F	150F	-	-	-	-	-	3.25	4.00	4.06	5.00	6.00	8.00	12.50	12.50	-	15.69	-	-	
Center Inlet to Discharge	B	300F	-	-	-	-	-	5.00	5.88	6.43	7.88	10.50	13.25	12.19	14.50	-	18.81	-	-	
Center Discharge to Inlet	F	300F	-	-	-	-	-	3.50	4.31	4.43	5.31	6.50	8.50	13.19	13.25	-	16.50	-	-	
Common Dimensions (Globe and Angle)																				
Width	C		4.25	4.25	4.88	4.88	6.13	6.50	8.19	9.25	10.88	16.75	21.63	22.13	26.00	26.00	32.00	49.68	49.68	
Height (To Stem Cap) Globe	E		2.88	2.88	4.38	4.38	4.38	4.75	7.50	8.00	9.15	11.75	14.91	23.31	26.75	26.80	31.40	45.75	45.75	
Height (To Stem Cap) Angle	E		-	-	4.38	4.38	4.38	4.75	7.50	8.00	9.15	11.75	14.91	20.00	23.75	N/A	28.50	N/A	N/A	
Body Port Tapping	FNPT	1/4	1/4	3/8	3/8	3/8	3/8	3/8	3/8	3/8	3/8	3/8	1/2	3/4	3/4	3/4	3/4	3/4	3/4	
Stem Cap Plug	MNPT	3/8	3/8	3/8	3/8	3/8	3/8	3/8	3/8	3/8	3/8	3/8	1/2	3/4	3/4	3/4	3/4	3/4	3/4	
Cover Port Tapping	FNPT	3/8	3/8	3/8	3/8	3/8	3/8	3/8	3/8	3/8	3/8	1/2	1/2	3/4	3/4	3/4	3/4	3/4	3/4	
Valve Stroke			1/2	1/2	1/2	1/2	1/2	9/16	1	1 1/8	1 7/16	1 11/16	2 7/8	3 1/4	3 3/4	3 1/2	4 3/4	6	6	
Displaced Bonnet Volume (Gallons)			0.005	0.005	0.007	0.007	0.007	0.018	0.066	0.090	0.20	0.56	1.67	1.50	2.30	2.30	6.75	14.75	14.75	
Approx. Shipping Weight (Lbs.)			15	15	20	20	20	40	65	100	175	400	650	900	1300	1400	2300	4900	5000	
Capacities (USPGM) Globe & Angle																				
CV - Globe			7	7	28	30	32	55	80	110	200	460	800	1250	1750	2100	3000	7500	7600	
CV - Angle			-	-	24	24	26	63	90	135	230	535	950	1400	2450	-	4000	-	-	
Continuous (Globe)			12	28	49	76	110	208	300	460	800	1800	3100	4900	7000	8500	11000	17250	25000	
Intermittent (Globe)			15	34	61	95	137	260	375	575	1000	2250	3875	6100	8800	11500	14250	21600	31200	
Momentary (Globe)			28	62	110	170	250	470	670	1030	1800	4000	7000	11000	16000	19000	25000	39000	56200	
Maximum Pressure Ratings (Ductile Only)																				
PSI*	FNPT		600	600	600	600	600	600	600	600	-	-	-	-	-	-	-	-	-	
PSI	150F		-	-	-	-	250	250	250	250	250	250	250	250	250	250	250	250	250	
PSI*	300F		-	-	-	-	600	600	600	600	600	600	600	600	600	600	600	600	600	
*Valves rated and stamped 400 PSI as standard. Valves rated and stamped 600 PSI on request.																				
Maximum Temperature																				
Fahrenheit			180°	180°	180°	180°	180°	180°	180°	180°	180°	180°	180°	180°	180°	180°	180°	180°	180°	

Note: Drilled as per ANSI B16.42 or threaded as per ANSI B1.20.1
 Note: Class 150 machined flat faced / Class 300 machined raised faced.
 Note: Castings are based on ANSI Class 150 or Class 300 standards.
 Note: Consult the factory if working pressure exceeds 300 psi.
 Note: Dimensions shown are different for Anti-Cav products. See Anti Cavitation bulletin.

For Anti-Cavitation
 Valves See
 Page 57

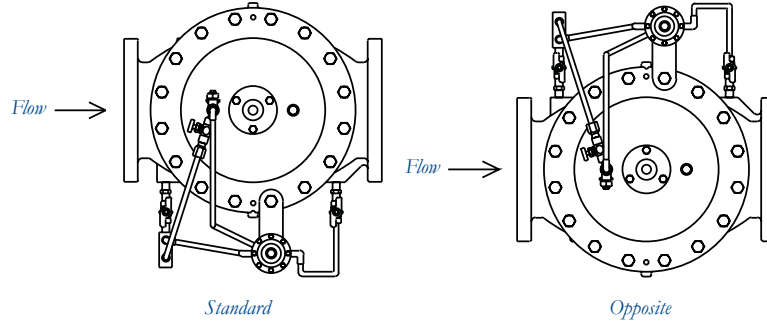

Add a minimum 6" (150mm) on one side, for pilot system. Pilot system is installed as "standard" ("opposite" please specify). Dimensions are nominal. Allow 1/8" (3mm) for machining tolerance. Allow one to three feet for installation and maintenance clearances. Consult factory for certified dimensions. Install with stem vertical is preferred, 10" (250mm) and larger is mandatory.

ANSI Valve Data (Metric Units)

Size	DWG	Standard	Flat Diaphragm System										Rolling Diaphragm System						
MM	REF	ANSI	15	20	25	32	40	50	65	80	100	150	200	250	300	350	400	500	600
All figures show in mm unless otherwise stated																			
Globe Dimensions																			
Layer Length	A	FNPT	114	114	171	171	171	238	279	343	-	-	-	-	-	-	-	-	-
Centerline to Bottom	D	FNPT	44	44	64	64	64	70	86	93	-	-	-	-	-	-	-	-	-
Layer Length	A	150F	-	-	-	-	216	238	279	305	381	508	645	756	864	787	1051	1718	1562
Centerline to Bottom	D	150F	-	-	-	-	70	76	89	95	117	142	200	217	241	267	298	436	435
Layer Length	A	300F	-	-	-	-	229	254	295	337	397	533	670	790	902	826	1105	1757	1607
Centerline to Bottom	D	300F	-	-	-	-	83	83	95	105	129	161	200	236	260	292	324	436	499
Angle Dimensions																			
Center Inlet to Discharge	B	FNPT	-	-	86	86	86	119	140	168	-	-	-	-	-	-	-	-	-
Center Discharge to Inlet	F	FNPT	-	-	76	76	76	83	102	118	-	-	-	-	-	-	-	-	-
Center Inlet to Discharge	B	150F	-	-	-	-	-	121	140	154	191	254	324	292	349	-	457	-	-
Center Discharge to Inlet	F	150F	-	-	-	-	-	83	102	103	127	152	203	318	318	-	399	-	-
Center Inlet to Discharge	B	300F	-	-	-	-	-	127	149	163	200	267	337	310	368	-	478	-	-
Center Discharge to Inlet	F	300F	-	-	-	-	-	89	109	113	135	165	216	335	337	-	419	-	-
Common Dimensions (Globe and Angle)																			
Width	C		108	108	124	124	156	165	208	235	276	425	549	562	660	660	813	1262	1262
Height (To Stem Cap) Globe	E		73	73	111	111	111	121	191	203	232	298	379	592	679	681	798	1162	1162
Height (To Stem Cap) Angle	E		-	-	111	111	111	121	191	203	232	298	379	506	603	-	724	-	-
Body Port Tapping	FNPT	Inches	1/4	1/4	3/8	3/8	3/8	3/8	3/8	3/8	3/8	3/8	1/2	3/4	3/4	3/4	3/4	3/4	3/4
Stem Cap Plug	MNPT	Inches	3/8	3/8	3/8	3/8	3/8	3/8	3/8	3/8	3/8	3/8	3/8	3/4	3/4	3/4	3/4	3/4	3/4
Cover Port Tapping	FNPT	Inches	3/8	3/8	3/8	3/8	3/8	3/8	3/8	3/8	3/8	1/2	1/2	3/4	3/4	3/4	3/4	3/4	3/4
Valve Stroke		mm	13	13	13	13	13	14	25	29	37	43	73	83	95	89	120	150	150
Displaced Bonnet Volume (Litres)			0.02	0.02	0.03	0.03	0.03	0.07	0.25	0.34	0.76	2.12	6.32	5.67	8.69	8.69	25.55	55.83	55.83
Approx. Shipping Weight (Kilograms)			7.00	7.00	9.00	9.00	9.00	18.00	29.00	45.00	79.00	181.00	295.00	480	590	635	1043	2227	2268
Capacities (L/s) Globe & Angle																			
CV - Globe			0.2	0.2	0.7	0.7	0.8	1.3	1.9	2.6	4.8	10.9	19.0	29.7	41.6	49.9	71.3	178.1	180.5
CV - Angle			-	-	0.6	0.6	0.6	1.5	2.1	3.2	5.5	12.7	22.6	33.3	58.2	-	95.0	-	-
Continuous (Globe)			0.76	1.77	3.09	4.79	6.94	13.12	18.93	29.02	50.47	113.56	195.58	309.14	441.63	536.27	693.99	1088.31	1577.25
Intermittent (Globe)			0.95	2.15	3.85	5.99	8.64	16.40	23.66	36.28	63.09	141.95	244.47	384.85	555.19	725.54	899.04	1362.75	1968.41
Momentary (Globe)			1.77	3.91	6.94	10.73	15.77	29.65	42.27	64.98	113.56	252.36	441.63	693.99	1009.44	1198.71	1577.25	2460.52	3545.67
Maximum Pressure Ratings (Ductile Only)																			
Bar*	FNPT		41	41	41	41	41	41	41	41	-	-	-	-	-	-	-	-	-
Bar	150F		-	-	-	-	17	17	17	17	17	17	17	17	17	17	17	17	17
Bar*	300F		-	-	-	-	41	41	41	41	41	41	41	41	41	41	41	41	41
* Valves rated and stamped 28 bar as standard. Valves rated and stamped 41 bar on request.																			
Maximum Temperature																			
Celsius			82°	82°	82°	82°	82°	82°	82°	82°	82°	82°	82°	82°	82°	82°	82°	82°	82°

Note: Castings are based on ANSI Class 150 or Class 300 standards.

Note: Ansi Flanges drilled to ISO 2531/BS54504 PN 10, 16, 25, or 40, or threaded BSPT.

Note: Consult the factory if working pressure exceeds 20 Bar.

Note: Dimensions shown are different for Anti-Cav products. See Anti Cavitation bulletin.

For Anti-Cavitation
Valves See
Page 57

Model 106-PG

ISO Valve Data (Metric Units):

Size	DWG	Standard	Flat Diaphragm System												Rolling Diaphragm System					
			REF	ISO	15	20	25	32	40	50	65	80	100	150	200	250	300	350	400	500
All figures show in mm unless otherwise stated																				
Globe Dimensions																				
Lay Length	A	BSPT	114	114	171	171	171	238	279	343	-	-	-	-	-	-	-	-	-	-
Centerline to Bottom	D	BSPT	44	44	64	64	64	70	86	93	-	-	-	-	-	-	-	-	-	-
Lay Length	A	PN10/PN16	-	-	-	-	229	238	279	318	381	508	645	756	864	787	1051	1718	1562	-
Centerline to Bottom	D	PN10/PN16	-	-	-	-	83	76	89	100	117	142	200	217	241	267	298	436	435	-
Lay Length	A	PN25/PN40	-	-	-	-	229	238	279	318	397	533	670	790	864	826	1105	1757	1607	-
Centerline to Bottom	D	PN25/PN40	-	-	-	-	83	76	89	100	129	161	200	243	241	292	324	436	499	-
Angle Dimensions																				
Center Inlet to Discharge	B	BSPT	-	-	86	86	86	119	140	168	-	-	-	-	-	-	-	-	-	-
Center Discharge to Inlet	F	BSPT	-	-	76	76	76	83	102	118	-	-	-	-	-	-	-	-	-	-
Center Inlet to Discharge	B	PN10/PN16	-	-	-	-	-	121	140	163	191	254	324	292	349	-	457	-	-	-
Center Discharge to Inlet	F	PN10/PN16	-	-	-	-	-	83	102	113	127	152	203	318	318	-	399	-	-	-
Center Inlet to Discharge	B	PN25/PN40	-	-	-	-	-	121	140	163	200	267	337	310	349	-	478	-	-	-
Center Discharge to Inlet	F	PN25/PN40	-	-	-	-	-	83	102	113	135	165	216	335	318	-	419	-	-	-
Common Dimensions (Globe and Angle)																				
Width	C		108	108	124	124	156	152	208	235	276	425	549	562	660	660	813	1262	1262	-
Height (To Stem Cap) Globe	E		73	73	111	111	111	121	191	203	232	298	379	592	679	681	798	1162	1162	-
Height (To Stem Cap) Angle	E		-	-	111	111	111	121	191	203	232	298	379	508	603	-	724	-	-	-
Body Port Tapping	FNPT	Inches	1/4	1/4	3/8	3/8	3/8	3/8	3/8	3/8	3/8	3/8	1/2	3/4	3/4	3/4	3/4	3/4	3/4	3/4
Stem Cap Plug	MNPT	Inches	3/8	3/8	3/8	3/8	3/8	3/8	3/8	3/8	3/8	3/8	3/8	3/4	3/4	3/4	3/4	3/4	3/4	3/4
Cover Port Tapping	FNPT	Inches	3/8	3/8	3/8	3/8	3/8	3/8	3/8	3/8	3/8	1/2	1/2	3/4	3/4	3/4	3/4	3/4	3/4	3/4
Valve Stroke		mm	13	13	13	13	13	14	25	29	37	43	73	83	95	89	120	150	150	-
Displaced Bonnet Volume (Litres)			0.02	0.02	0.03	0.03	0.03	0.07	0.25	0.34	0.76	2.12	6.32	5.67	8.69	8.69	25.55	55.83	55.83	-
Approx. Shipping Weight (Kilograms)			7	7	9	9	9	18	29	45	79	181	295	480	590	635	1043	2227	2268	-
Capacities (L/s) Globe & Angle																				
CV - Globe			0.2	0.2	0.7	0.7	0.8	1.3	1.9	2.6	4.8	10.9	19.0	29.7	41.6	49.9	71.3	178.1	180.5	-
CV - Angle			-	-	0.6	0.6	0.6	1.5	2.1	3.2	5.5	12.7	22.6	33.3	58.2	-	95.0	-	-	-
Continuous (Globe)			0.76	1.77	3.09	4.79	6.94	13.12	18.93	29.02	50.47	113.56	195.58	309.14	441.63	536.27	693.99	1088.31	1577.25	-
Intermittent (Globe)			0.95	2.15	3.85	5.99	8.64	16.40	23.66	36.28	63.09	141.95	244.47	384.85	555.19	725.54	899.04	1362.75	1968.41	-
Momentary (Globe)			1.77	3.91	6.94	10.73	15.77	29.65	42.27	64.98	113.56	252.36	441.63	693.99	1009.44	1198.71	1577.25	2460.52	3545.67	-
Maximum Pressure Ratings (Ductile Only)																				
Bar		BSPT	28	28	28	28	28	28	28	28	-	-	-	-	-	-	-	-	-	-
Bar		PN16	-	-	-	-	16	16	16	16	16	16	16	16	16	16	16	16	16	16
Bar		PN25	-	-	-	-	25	25	25	25	25	25	25	25	25	25	25	25	25	25
Maximum Temperature																				
Celsius			82°	82°	82°	82°	82°	82°	82°	82°	82°	82°	82°	82°	82°	82°	82°	82°	82°	82°

For Anti-Cavitation Valves See Page 57

AVAILABLE OPTIONS:

VALVE POSITION INDICATORS:

- Model X107 stem mounted position indicators
- Model X129 limit switch assembly with S.P.D.T. limit switch
- Model X136M/X156 analog position transmitters (4 to 20 mA)

All of which may be installed at the factory or as a field modification.

MATERIALS OF CONSTRUCTION for individual components can be upgraded from ductile iron, bronze and brass to stainless steel, for most sizes. Consult with the factory.

OXY NITRIDE STEM provides extra protection against mineral deposits. See Main Valve Options Section.

INTERNAL DROP CHECK option provides a built-in, drop check to mechanically prevent reverse flow. See Main Valve Options Section.

INTERNAL NEEDLE STEM VALVE provides a restriction in the pilot circuit that is proportional to valve lift. See Pilots & Accessories Section.

EXTERNAL SPRING LIFT See Main Valve Options Section.

MODEL PGM provides a fully operational back-up system in the event of a diaphragm or pilot failure. See High Performance Section.

ANTI-CAVITATION TRIM - The model 106-PG-AC allows very high pressure drops in one valve, while retaining the standard 106 valve features. See High Performance Section.

GROOVED ENDS - See Main Valve Options Section.

RECLAIM WATER - For Grey and Reclaim Water applications. See Main Valve Options Section.

PILOTS & ACCESSORIES - Singer Valve offers a wide range of Pilots & Accessories. See Pilots & Accessories Section.

SELECTION:

Automatic control valves operate by introducing or exhausting water from above the diaphragm at controlled rates. A pressure differential is required and is either inlet to outlet or inlet to atmosphere, depending on the application. Valves are sized to provide an appropriate pressure drop for each application. Consult the factory if the application does not have a minimum 5 psi (.35 bar) to atmosphere or 10 psi (.7 bar) differential between inlet and outlet pressure.

Singer control valves are designed for use with clean potable water. Applications for other media are possible. Consult with the factory.

Careful consideration of the possibility of cavitation must be given. Anti-cavitation trim is available to control the cavitation, reduce noise and prevent damage. Refer to model 106-(-)-AC in High Performance Section and consult with the factory.

The Singer model 106-PG single chambered valve is the basic valve used in practically every model bearing the 106 description. The pilot systems are designed to meet the functional and performance requirements of specific applications. Sizing is ultimately determined by the specific application.

SPECIFICATIONS:

- Valve(s) shall be a hydraulically operated globe (angle) valve. The inner valve assembly shall be top and bottom guided by means of easily replaceable bearing bushings. The inner valve assembly shall be the only moving part and shall be securely mounted on a 316 stainless steel stem. The stainless steel stem shall be provided with wrench flats on all valves 1" (25mm) to 8" (200mm), for ease of assembly and maintenance.
- All pressure containing components shall be constructed of ASTM A536-65/45/12 ductile iron. The flanges shall be designed to ANSI Class 150 or Class 300 standards. Flange drilling to ANSI shall be standard however British, ISO and other drillings shall be available upon request.
- Valve(s) shall have a protective fusion bonded epoxy coating internally and externally. The protective fusion bonded epoxy coating shall conform to the ANSI/AWWA C116/A21.16 (current version) specification.
- Valve(s) 8" (200mm) and smaller shall provide smooth "frictionless" motion with actuation being achieved by the use of a flat style EPDM diaphragm. They shall be constructed of nylon fabric bonded with synthetic rubber. The diaphragms shall not be used as a seating surface. No lip seals or packing may be used to seal the actuator.
- Valve(s) 10" (250mm) and larger shall provide smooth "frictionless" motion and maximum low flow stability with actuation being achieved by the use of the Singer rolling diaphragm technology. The diaphragms shall not be used as a seating surface. No lip seals or packing may be used to seal the actuator.
- The valve cover shall have a separate stem cap giving access to the stem for alignment check, spring installation and ease of assembly.
- On valve(s) 1" (25mm) and larger, bonnets shall be accurately located to bodies utilizing locating pins. Locating pins shall eliminate corrosion resulting from the use of uncoated ductile iron to ductile iron surfaces.
- Valve(s) 3" (80mm) and larger shall have the 316 stainless steel seat, bolted in place, utilizing "Spiralock" thread tapping technology. The 316 stainless steel seat ring shall be easily replaceable without special tools.
- The valve(s) shall form a drip tight seal between the stationary stainless steel seat ring and the resilient disc, which has a rectangular cross-section and is retained by clamping on three and one half sides. The resilient disc shall be constructed of Buna or EPDM for normal service conditions.
- All external fasteners shall be 18/8 stainless steel with 18/8 washers.
- All repairs and maintenance shall be possible without removing the valve from the line. To facilitate easy removal and replacement of the inner valve assembly and to reduce unnecessary wear on the guide, the stem shall be vertical when the valve is mounted in a horizontal line.
- Each valve shall be tested prior to shipment. The standard test shall include a pressure test and a full functional, operational test when pilots and accessories are fitted to suit a particular application.
- The valve(s) shall be covered by a minimum three year (3) warranty against defects in materials and workmanship. The stainless steel seat ring shall be covered by a lifetime replacement warranty.
- The valve shall be a Singer Model.... Refer to other Catalog Sections for further details.

Singer Valve Inc.

12850 - 87th Avenue • Surrey, British Columbia, Canada V3W 3H9

Tel: 604 594 5404 • Fax: 604 594 8845 • Toll-Free Fax (US & Canada): 1 800 663 7266

E-Mail: singer@singervalve.com • singervalve.com*An ISO 9001:2000 Registered Company*