

Flange Dimensions—Ductile Iron Valves

Standard: ANSI B16.42 - 1998 - Class 150 and 300

Nominal Pipe Size	Diameter of Flange		Diameter of Bolt Circle		Number of Bolts		Diameter of Bolt Holes	
	150#	300#	150#	300#	150#	300#	150#	300#
Pressure Class								
1.5	5.00	6.12	3.88	4.50	4	4	5/8"	7/8"
2	6.00	6.50	4.75	5.00	4	8	3/4"	3/4"
2.5	7.00	7.50	5.50	5.88	4	8	3/4"	7/8"
3	7.50	8.25	6.00	6.62	4	8	3/4"	7/8"
4	9.19	10.19	7.50	7.88	8	8	3/4"	7/8"
6	11.19	12.69	9.50	10.62	8	12	7/8"	7/8"
8	13.50	15.00	11.75	13.00	8	12	7/8"	1"
10	16.00	17.50	14.25	15.25	12	16	1"	1-1/8"
12	19.00	20.50	17.00	17.75	12	16	1"	1-1/4"
14	21.00	23.00	18.75	20.25	12	20	1-1/8"	1-1/4"
16	23.50	25.50	21.25	22.50	16	20	1-1/8"	1-3/8"
18	25.00	28.00	22.75	24.75	16	24	1-1/4"	1-3/8"
20	27.50	30.50	25.00	27.00	20	24	1-1/4"	1-3/8"
24	33.00	36.00	29.50	32.00	20	24	1-3/8"	1-5/8"
30	38.75	43.00	36.00	39.25	28	28	1-3/8"	2"
36	46.50	50.00	42.75	46.00	32	32	1-5/8"	2-1/4"

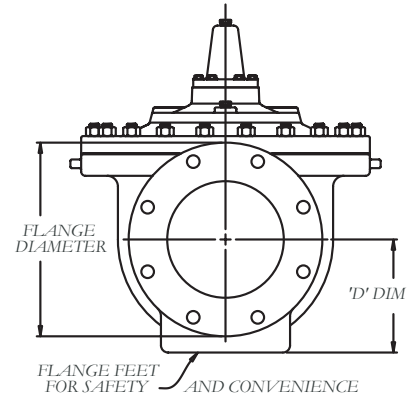

Dimension in (inches)

Standard: ISO 2531 - 1998

Nominal Pipe Size	Diameter of Flange				Diameter of Bolt Circle				Diameter of Bolt Holes				Number of Bolts			
	PN-10	PN-16	PN-25	PN-40	PN-10	PN-16	PN-25	PN-40	PN-10	PN-16	PN-25	PN-40	PN-10	PN-16	PN-25	PN-40
40	155	155	155	155	110	110	110	110	19	19	19	19	4	4	4	4
50	152	152	152	152	125	125	125	125	19	19	19	19	4	4	4	4
65	178	178	178	178	145	145	145	145	19	19	19	19	4	4	8	8
80	200	200	200	200	160	160	160	160	19	19	19	19	8	8	8	8
100	233	233	260	260	180	180	190	190	19	19	23	23	8	8	8	8
150	285	285	310	310	240	240	250	250	23	23	28	28	8	8	8	8
200	343	343	381	381	295	295	310	320	23	23	28	31	8	12	12	12
250	406	406	445	445	350	355	370	385	23	28	31	34	12	12	12	12
300	483	483	483	520	400	410	430	450	23	28	31	34	12	12	16	16
350	533	533	584	584	460	470	490	510	23	28	34	37	16	16	16	16
400	597	597	648	648	515	525	550	585	28	31	37	40	16	16	16	16
500	699	699	775	775	620	650	660	670	28	34	37	43	20	20	20	20
600	838	838	838	915	725	770	770	795	31	37	40	49	20	20	20	20
700	895	910	960	995	840	840	875	900	31	37	43	48	24	24	24	24
800	1,015	1,025	1,085	1,140	950	950	990	1,030	34	40	49	56	24	24	24	24
900	1,115	1,125	1,185	1,285	1,050	1,050	1,090	1,170	34	40	49	56	28	28	28	28

Dimension in (mm)

NOTE:

ISO flange diameters may vary slightly from the standard, as the flange bolt pattern is drilled on an ANSI valve flange