

# MODEL 160-RF:

## RATE OF FLOW CONTROL PILOT

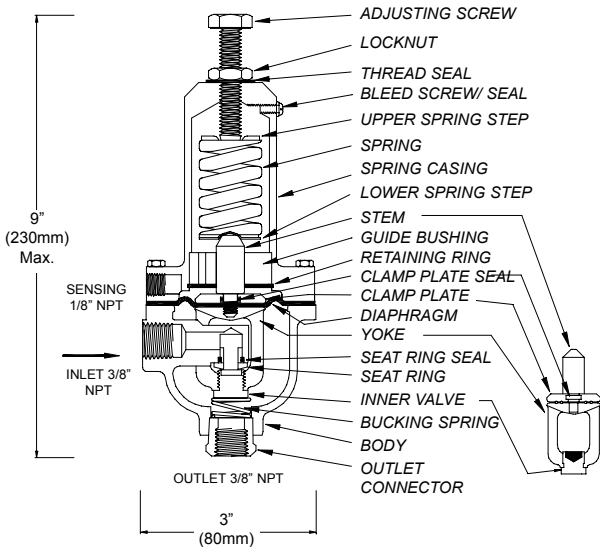

SCHEMATIC A0709D